

PLAN COMPACT VENTIL

The Plan Compact Ventil combines the timeless beautiful elegance of a perfectly flat front with the advantages of an integrated valve connection. It has a perfect panel front, so that from the front a smooth surface can be seen, without any disturbing elements such as overlapping side covers. The integrated valve body enables connection from below (2 connections ½" BSP, distance 50 mm). As standard it is provided for a 2 pipe system, with a 1 pipe connection set it can naturally also be integrated into a 1 pipe system.

- Accessories included in the packaging and the price : brackets, screws and plugs.
- Connections : 4 x ½" BSP, ISO 228, at the side + 2 x ½" BSP, ISO 228, at the bottom, distance 50 mm. The pipe system for the supply of hot water is integrated on the right side and the Kv-adjustable thermostatic valve body is already integrated as well as 1 airvent and 2 blank caps.
- Installation : type 11 : fixing bracket
type 21S, 22 and 33 : FZ brackets
- Colours : prices are based on white RAL 9016. Other RAL and special colours are available upon request with a 25% supplement. See p. 131/158 for more details and colour options.
- Accessories : see p. 152.

CONNECTION OPTIONS

dimensions in mm

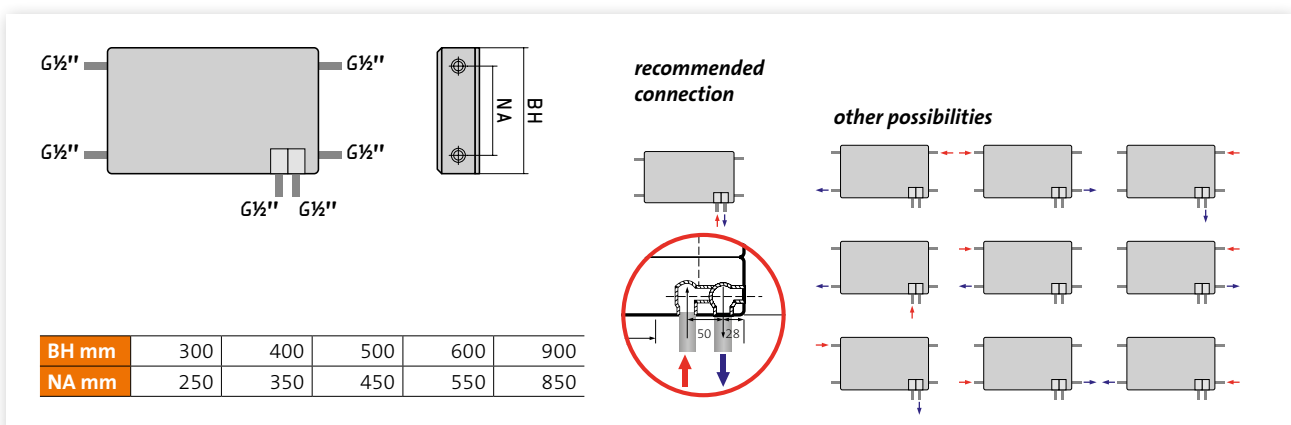

PLAN COMPACT VENTIL

INSTALLATION

dimensions in mm

types 215, 22, 33

type 11

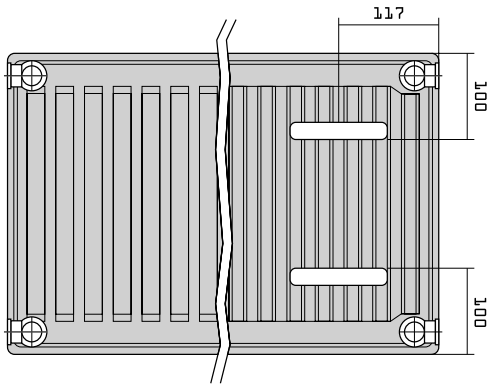

Standard brackets



(type 11)

Invisible bracket (Monclac)

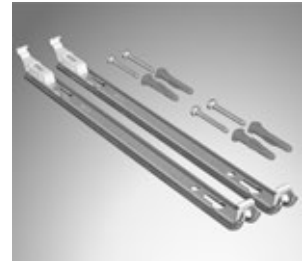

(types 215, 22, 33)

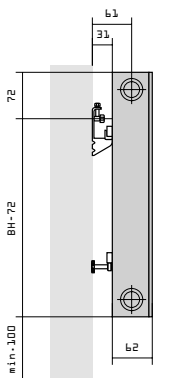

type 11

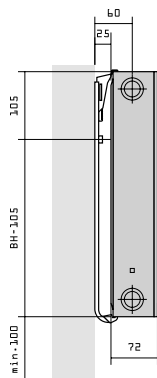

type 215

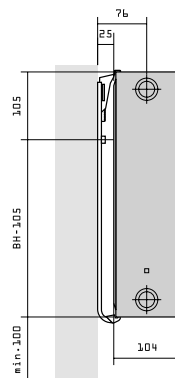

type 22

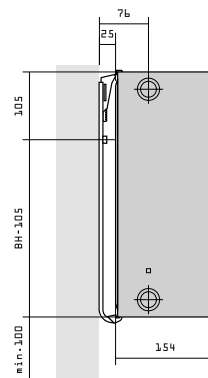

type 33 (right)

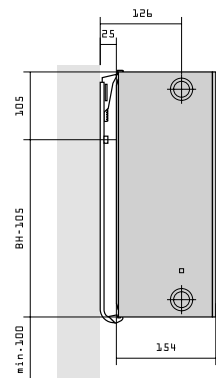

type 33 (left)

water content : l/m

type	300	400	500	600	900
11	1.50	2.20	2.90	3.40	4.50
215			5.20	6.10	8.80
22	3.20	4.20	5.20	6.10	8.80
33	5.10	6.30	7.50	8.80	13.00

weight : kg/m

type	300	400	500	600	900
11	11.70	16.10	16.10	24.80	36.50
215			23.70	33.70	49.80
22	19.10	25.10	27.00	38.00	58.90
33	26.90	36.70	42.20	56.40	84.90

PLAN COMPACT VENTIL

type 11



ORDER CODE : FCV11XXXXYYY
EXAMPLE : FCV116001200
radiator _____
type _____
height _____
length _____



length	height					
	300	400	500	600	900	
400	75/65/20 Watt	212	272	329	384	539
	55/45/20 Watt	110	141	171	200	277
	£	156.21	128.76	138.40	146.42	174.14
500	75/65/20 Watt	265	340	412	481	674
	55/45/20 Watt	137	177	214	249	346
	£	169.37	138.40	149.20	158.84	191.80
600	75/65/20 Watt	317	408	494	577	808
	55/45/20 Watt	165	212	256	299	416
	£	187.71	147.29	159.96	171.00	210.48
700	75/65/20 Watt	370	476	576	673	943
	55/45/20 Watt	192	247	299	349	485
	£	206.16	156.21	170.32	183.53	231.95
800	75/65/20 Watt	423	544	658	769	1078
	55/45/20 Watt	220	283	342	399	554
	£	224.20	165.15	180.69	195.62	252.11
900	75/65/20 Watt	476	612	741	865	1212
	55/45/20 Watt	247	318	385	449	624
	£	242.27	173.35	191.02	207.46	270.92
1000	75/65/20 Watt	529	680	823	961	1347
	55/45/20 Watt	275	353	427	499	693
	£	260.89	181.95	200.81	219.49	293.28
1100	75/65/20 Watt	582	748	905	1057	1482
	55/45/20 Watt	302	389	470	549	762
	£	279.86	191.74	212.36	234.25	312.65
1200	75/65/20 Watt	635	816	988	1153	1616
	55/45/20 Watt	330	424	513	599	831
	£	298.99	201.54	224.79	246.19	331.90
1400	75/65/20 Watt	741	952	1152	1345	1886
	55/45/20 Watt	385	494	598	699	970
	£	339.48	221.48	248.42	275.54	376.04
1600	75/65/20 Watt	846	1088	1317	1538	2155
	55/45/20 Watt	440	565	684	798	1109
	£	379.56	240.90	274.05	302.29	421.55
1800	75/65/20 Watt	952	1224	1481	1730	2425
	55/45/20 Watt	495	636	769	898	1247
	£	426.56	269.99	311.46	339.24	468.24
2000	75/65/20 Watt	1058	1360	1646	1922	2694
	55/45/20 Watt	550	706	855	998	1386
	£	467.89	291.98	333.22	368.40	511.47
2300	75/65/20 Watt	1217	1564	1893	2210	
	55/45/20 Watt	632	812	983	1148	
	£	490.23	312.35	357.64	396.36	
2600	75/65/20 Watt	1375	1768	2140	2499	
	55/45/20 Watt	715	918	1111	1297	
	£	586.52	353.25	406.44	452.41	
3000	75/65/20 Watt	1587	2040	2469	2883	
	55/45/20 Watt	824	1060	1282	1497	
	£	667.61	395.65	456.69	509.13	

value n	1.2820	1.2824	1.2827	1.2831	1.3013
---------	--------	--------	--------	--------	--------

according EN 442 - 75/65/20 °C (ΔT 50) and 55/45/20 °C (ΔT 30)
To calculate from Watts to BTU's multiply by 3.412 (1000 watts x 3.412 = 3,412 btu's).

TECHNICAL PRICE LIST
01/2015

PLAN COMPACT VENTIL

type 21S



ORDER CODE : FCV21XXXXYYY
EXAMPLE : FCV216001200
radiator _____
type _____
height _____
length _____



length	height					
	300	400	500	600	900	
400	75/65/20 Watt			445	515	706
	55/45/20 Watt			230	266	357
	£			153.55	163.09	194.19
500	75/65/20 Watt			557	644	883
	55/45/20 Watt			288	332	446
	£			166.68	178.38	215.60
600	75/65/20 Watt			668	773	1059
	55/45/20 Watt			345	398	535
	£			179.96	193.47	238.05
700	75/65/20 Watt			779	902	1236
	55/45/20 Watt			403	465	624
	£			193.40	209.52	268.73
800	75/65/20 Watt			890	1030	1412
	55/45/20 Watt			461	531	713
	£			206.39	224.61	287.95
900	75/65/20 Watt			1002	1159	1589
	55/45/20 Watt			518	598	802
	£			219.71	240.04	310.84
1000	75/65/20 Watt			1113	1288	1765
	55/45/20 Watt			576	664	891
	£			232.31	257.71	337.08
1100	75/65/20 Watt			1224	1417	1942
	55/45/20 Watt			633	731	981
	£			246.87	273.30	360.62
1200	75/65/20 Watt			1336	1546	2118
	55/45/20 Watt			691	797	1070
	£			262.08	288.67	383.90
1400	75/65/20 Watt			1558	1803	2471
	55/45/20 Watt			806	930	1248
	£			295.34	326.04	436.35
1600	75/65/20 Watt			1781	2061	2824
	55/45/20 Watt			921	1063	1426
	£			323.98	359.58	489.54
1800	75/65/20 Watt			2003	2318	3177
	55/45/20 Watt			1036	1195	1605
	£			363.10	399.38	540.40
2000	75/65/20 Watt			2226	2576	3530
	55/45/20 Watt			1151	1328	1783
	£			390.16	433.78	591.71
2300	75/65/20 Watt			2560	2962	
	55/45/20 Watt			1324	1527	
	£			419.04	467.55	
2600	75/65/20 Watt			2894	3349	
	55/45/20 Watt			1497	1727	
	£			479.39	537.57	
3000	75/65/20 Watt			3339	3864	
	55/45/20 Watt			1727	1992	
	£			540.16	606.18	

value n			1.2907	1.2967	1.3371
---------	--	--	--------	--------	--------

according EN 442 - 75/65/20 °C (ΔT 50) and 55/45/20 °C (ΔT 30)
To calculate from Watts to BTU's multiply by 3.412 (1000 watts x 3.412 = 3,412 btu's).

TECHNICAL PRICE LIST
01/2015

PLAN COMPACT VENTIL

type 22



ORDER CODE : **FCV22XXXXYYY**
EXAMPLE : FCV226001200
radiator _____
type _____
height _____
length _____

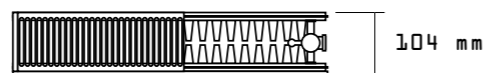

length	height					
	300	400	500	600	900	
400	75/65/20 Watt	375	479	578	670	920
	45/35/20 Watt	193	245	294	340	462
	£	130.26	148.80	164.74	173.99	212.19
500	75/65/20 Watt	469	599	722	838	1151
	45/35/20 Watt	241	307	368	425	578
	£	137.89	161.97	177.69	193.06	238.21
600	75/65/20 Watt	562	719	866	1006	1381
	45/35/20 Watt	289	368	442	510	693
	£	145.62	174.43	193.17	210.48	265.21
700	75/65/20 Watt	656	839	1011	1173	1611
	45/35/20 Watt	338	430	515	595	809
	£	154.24	186.34	207.64	229.18	295.80
800	75/65/20 Watt	750	958	1155	1341	1841
	45/35/20 Watt	386	491	589	680	924
	£	161.61	198.87	222.80	245.34	324.26
900	75/65/20 Watt	843	1078	1300	1508	2071
	45/35/20 Watt	434	552	662	765	1040
	£	168.17	211.28	238.10	262.76	351.62
1000	75/65/20 Watt	937	1198	1444	1676	2301
	45/35/20 Watt	482	614	736	850	1155
	£	176.49	223.81	252.86	286.01	382.25
1100	75/65/20 Watt	1031	1318	1588	1844	2531
	45/35/20 Watt	531	675	809	935	1271
	£	185.20	237.02	269.60	300.69	410.33
1200	75/65/20 Watt	1124	1438	1733	2011	2761
	45/35/20 Watt	579	736	883	1020	1386
	£	193.91	251.31	287.09	318.47	438.01
1400	75/65/20 Watt	1312	1677	2022	2346	3221
	45/35/20 Watt	675	859	1030	1190	1617
	£	215.33	280.82	322.22	359.97	499.74
1600	75/65/20 Watt	1499	1917	2310	2682	3682
	45/35/20 Watt	772	982	1177	1360	1848
	£	235.03	308.39	358.78	397.73	561.64
1800	75/65/20 Watt	1687	2156	2599	3017	4142
	45/35/20 Watt	868	1104	1325	1530	2080
	£	256.96	341.01	400.82	442.40	621.10
2000	75/65/20 Watt	1874	2396	2888	3352	4602
	45/35/20 Watt	965	1227	1472	1700	2311
	£	276.61	369.77	431.45	483.33	681.36
2300	75/65/20 Watt	2155	2755	3321	3855	
	45/35/20 Watt	1109	1411	1692	1955	
	£	295.58	398.19	465.72	519.83	
2600	75/65/20 Watt	2436	3115	3754	4358	
	45/35/20 Watt	1254	1595	1913	2210	
	£	333.45	454.96	534.87	599.11	
3000	75/65/20 Watt	2811	3594	4332	5028	
	45/35/20 Watt	1447	1841	2208	2549	
	£	370.98	511.87	603.73	677.07	

value n	1.3000	1.3098	1.3197	1.3295	1.3488
---------	--------	--------	--------	--------	--------

according EN 442 - 75/65/20 °C (ΔT 50) and 55/45/20 °C (ΔT 30)
To calculate from Watts to BTU's multiply by 3.412 (1000 watts x 3.412 = 3,412 btu's).

TECHNICAL PRICE LIST
01/2015

PLAN COMPACT VENTIL

type 33



ORDER CODE : **FCV33XXXXYYY**
EXAMPLE : FCV336001200
radiator _____
type _____
height _____
length _____

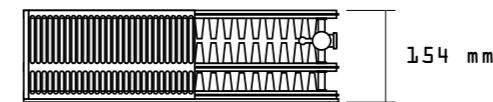

length	height					
	300	400	500	600	900	
400	75/65/20 Watt	526	666	798	923	1261
	45/35/20 Watt	268	339	404	465	629
	£	152.57	176.58	196.60	215.85	266.71
500	75/65/20 Watt	657	833	998	1154	1576
	45/35/20 Watt	335	423	505	581	786
	£	163.34	194.77	218.12	236.22	302.24
600	75/65/20 Watt	788	1000	1198	1384	1891
	45/35/20 Watt	403	508	606	698	944
	£	173.81	212.08	239.53	260.59	340.61
700	75/65/20 Watt	920	1166	1397	1615	2206
	45/35/20 Watt	470	593	707	814	1101
	£	185.59	230.71	260.38	286.63	381.89
800	75/65/20 Watt	1051	1333	1597	1846	2522
	45/35/20 Watt	537	678	808	930	1258
	£	195.73	248.03	281.44	309.65	420.73
900	75/65/20 Watt	1183	1499	1796	2076	2837
	45/35/20 Watt	604	762	909	1046	1415
	£	205.42	265.49	303.10	334.59	458.50
1000	75/65/20 Watt	1314	1666	1996	2307	3152
	45/35/20 Watt	671	847	1010	1163	1573
	£	216.92	283.27	324.16	361.75	498.59
1100	75/65/20 Watt	1445	1833	2196	2538	3467
	45/35/20 Watt	738	932	1111	1279	1730
	£	228.67	301.49	347.23	387.15	538.46
1200	75/65/20 Watt	1577	1999	2395	2768	3782
	45/35/20 Watt	805	1016	1212	1395	1887
	£	240.51	320.85	370.62	411.88	576.91
1400	75/65/20 Watt	1840	2332	2794	3230	4413
	45/35/20 Watt	939	1186	1414	1628	2202
	£	268.98	361.34	420.05	469.39	660.09
1600	75/65/20 Watt	2102	2666	3194	3691	5043
	45/35/20 Watt	1073	1355	1616	1860	2516
	£	295.58	399.61	467.85	522.56	743.38
1800	75/65/20 Watt	2365	2999	3593	4153	5674
	45/35/20 Watt	1208	1524	1818	2093	2831
	£	323.36	442.27	523.37	580.43	824.41
2000	75/65/20 Watt	2628	3332	3992	4614	6304
	45/35/20 Watt	1342	1694	2020	2325	3145
	£	349.61	481.84	568.23	634.20	904.70
2300	75/65/20 Watt	3022	3832	4591	5306	
	45/35/20 Watt	1543	1948	2323	2674	
	£	373.25	520.52	613.52	687.33	
2600	75/65/20 Watt	3416	4332	5190	5998	
	45/35/20 Watt	1744	2202	2627	3023	
	£	425.37	597.81	709.71	796.67	
3000	75/65/20 Watt	3942	4998	5988	6921	
	45/35/20 Watt	2013	2541	3031	3488	
	£	476.05	674.85	803.67	903.23	

value n	1.3159	1.3245	1.3331	1.3417	1.3612
---------	--------	--------	--------	--------	--------

according EN 442 - 75/65/20 °C (ΔT 50) and 55/45/20 °C (ΔT 30)
To calculate from Watts to BTU's multiply by 3.412 (1000 watts x 3.412 = 3,412 btu's).

TECHNICAL PRICE LIST
01/2015



Compact



Compact Ventil



Plan Compact



Plan Compact Ventil



*Plan Compact
 Ventil M*



Ramo Ventil

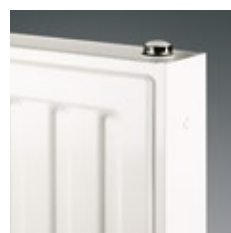

Vertical

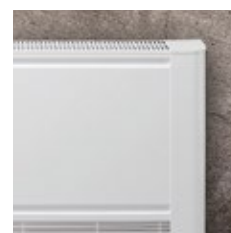

Safety Radiator

CHARACTERISTICS

- All Purmo panel radiators are produced with a cold rolled, high quality steel plate 125mm thick according to EN 10130.
- Certain models have vertical profiles of 33 mm or 50 mm. Other models are provided with a flat front.
- Testing pressure 13 bar. Ramo Ventil + Vertical : 8 bar.
- Working pressure 10 bar. Ramo Ventil + Vertical : 6 bar.
- Working temperature max. 110 °C.

COLOURS

Our standard colour is white RAL 9016. Other RAL and special colours are available upon request with a 25% supplement. See p. 131/158 for more details and colour options.

HEAT OUTPUT

Heat outputs were measured according to the EN 442 standard, with a water temperature of 75/65 °C and a room temperature of 20 °C (delta $\Delta T=50$).



PACKAGING

The radiators are protected with cardboard, including corner edge protections. The radiators are shrink-wrapped. The radiator can remain inside the packaging until installation is complete, to prevent any damage. The entire packaging is recyclable.

	Compact	Compact Ventil	Plan Compact	Plan Compact Ventil	Plan Compact Ventil M	Ramo Ventil	Vertical	Safety Radiator
profiled front - 33 mm	✓	✓	x	x	x	x	x	x
profiled front - 50 mm	x	x	x	x	x	x	✓	x
flat front	x	x	✓	✓	✓	✓	x	✓
testing pressure - bar	13	13	13	13	13	8	8	10
working pressure - bar	10	10	10	10	10	6	6	8
side covers	✓	✓	✓	✓	✓	✓	✓	✓
top grill	✓	✓	✓	✓	✓	✓	x	✓
welded on assembly points								
type 10	✓	✓	✓	✓	✓	✓	✓	-
type 11	✓	✓	✓	✓	✓	✓	-	✓
type 21S	✓	x	✓	x	x	✓	-	-
type 22	✓	x	✓	x	x	✓	-	✓
type 33	✓	x	✓	x	x	✓	-	-
number of connections	4	6	4	6	6	6	6	4
supply and return pipes visible	✓	x	✓	x	x	x	✓	✓
thermostatic valve body included	x	✓	x	✓	✓	✓	x	x
including attachment kit	✓	✓	✓	✓	✓	✓	✓	x
assembly packaging	✓	✓	✓	✓	✓	✓	x	✓
bore template	x	x	x	x	x	x	✓	x

✓ = yes; x = no

PRODUCTION & COATING PROCESS

Panel radiators are produced on fully automated, ultra-modern lines. They may be inspected at any time during the production process. The water tightness of each radiator is individually tested at the end of the production line.

Radiators are coated in a modern facility specially designed to protect the environment.

PRE-TREATMENT

Pre-treatment of radiators consists of degreasing and phosphating. In combination with the base coat, the phosphate layer provides excellent rust protection. After pre-treatment, the radiators are rinsed with deionised water.

COATING

This process consists of 2 main stages. First, the radiators are immersed in a 2nd generation KTL bath to cover them with a layer of anti-rust base by means of cataphoresis. They are then dried in hot air at a temperature of around 175 °C. The final coat is then applied. This powder coat of epoxy-polyester is applied to the radiators by electrophoresis. The powder coating is then heated at a temperature of almost 185 °C. Outstandingly hard and stable, the finishing coat is resistant to scratches, moisture and acids and complies with the DIN 55900 and EN 442 standards.

tested heat output Φ ,

According to EN 442:

$t_1 = 75^\circ\text{C}$, $t_2 = 65^\circ\text{C}$, $t_r = 20^\circ\text{C}$
Temperature difference $\Delta T = 50\text{K}$

For other ΔT 's use the following correction factor:

$$U_f = \left(\frac{\Delta T}{50}\right)^n$$

where n shown in table below.

Symbols used;

Φ = Greek letter pronounced fi

W = Watts (1W = 0.86kcal/h)

$^\circ\text{C}$ = Degrees Celsius

K = Degrees Kelvin

Definition	Symbol	Unit
Heat Output	Φ	W
Flow Temperature	t_1	$^\circ\text{C}$
Return Temperature	t_2	$^\circ\text{C}$
Temperature Drop	$t_1 - t_2$	K
Ambient Air Temperature	t_r	$^\circ\text{C}$
Temperature Difference	ΔT	K
$\frac{t_1 + t_2}{2} - t_r$		

temperature difference for other ΔT 's

For flow temperatures t_1 from 85°C to 40°C and return temperatures t_2 from 70°C to 35°C .

Please refer to specific radiator page for the correct n value.

temperature difference ΔT

Flow Temperature (t_1 , $^\circ\text{C}$)	Ambient Air Temperature (t_r , $^\circ\text{C}$)	Return Temperature (t_2 , $^\circ\text{C}$)							
		70	65	60	55	50	45	40	35
85	15	63	60	58	55	53	50	48	45
	18	60	57	55	52	50	47	45	42
	20	58	55	53	50	48	45	43	40
	22	56	53	51	48	46	43	41	38
80	24	54	51	49	46	44	41	39	36
	15	60	58	55	53	50	48	45	43
	18	57	55	52	50	47	45	42	40
	20	55	53	50	48	45	43	40	38
75	22	53	51	48	46	43	41	38	36
	24	51	49	46	44	41	39	36	34
	15	58	55	53	50	48	45	43	40
	18	55	52	50	47	45	42	40	37
70	20	53	50	48	45	43	40	38	35
	22	51	48	46	43	41	38	36	33
	24	49	46	44	41	39	36	34	31
	15	-	53	50	48	45	43	40	38
65	18	-	50	47	45	42	40	37	35
	20	-	48	45	43	40	38	35	33
	22	-	46	43	41	38	36	33	31
	24	-	44	41	39	36	34	31	29
60	15	-	-	48	45	43	40	38	35
	18	-	-	45	42	40	37	35	32
	20	-	-	43	40	38	35	33	30
	22	-	-	41	38	36	33	31	28
55	24	-	-	39	36	34	31	29	26
	15	-	-	-	43	40	38	35	33
	18	-	-	-	40	37	35	32	30
	20	-	-	-	38	35	33	30	28
50	22	-	-	-	36	33	31	28	26
	24	-	-	-	34	31	29	26	24
	15	-	-	-	-	38	35	33	30
	18	-	-	-	-	35	32	30	27
45	20	-	-	-	-	33	30	28	25
	22	-	-	-	-	31	28	26	23
	24	-	-	-	-	29	26	24	21
	15	-	-	-	-	-	33	30	28
40	18	-	-	-	-	-	30	27	25
	20	-	-	-	-	-	28	25	23
	22	-	-	-	-	-	26	23	21
	24	-	-	-	-	-	24	21	19
35	15	-	-	-	-	-	-	28	25
	18	-	-	-	-	-	-	25	22
	20	-	-	-	-	-	-	23	20
	22	-	-	-	-	-	-	21	18
30	24	-	-	-	-	-	-	19	16
	15	-	-	-	-	-	-	-	23
	18	-	-	-	-	-	-	-	20
	20	-	-	-	-	-	-	-	18
25	22	-	-	-	-	-	-	-	16
	24	-	-	-	-	-	-	-	14



Colour options

Our standard colour is white RAL 9016.

Any RAL or special colour is available on request*. To order simply add RAL or special colour code to the end of the order code eg. **AP06500830/3003** for a radiator in RAL 3003. Please note, there is a 25% supplement for non-standard colours.

*Some exclusions apply. Please see individual product pages for more details.

RAL colours

Purmo offers the choice of any RAL colour.



Special colours

Purmo also offers the following textured, metallic and shimmer metallic colours.

Textured



black textured
SO141

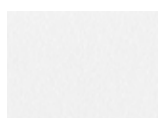

white textured
SO142

Metallic



cream
SO145



light grey
SO143

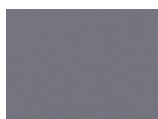

brown grey
SO144

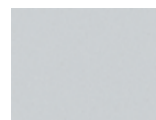

anodic natural
SO149



anodic bronze
SO146



anodic brown
SO147



anodic black
SO148

Shimmer metallic



metal alu
SO201



metal black
SO104



metal grey
SO102

Cancellation policy for non-stocked items

All our non-stocked and special colour items are made to order. Should an order be cancelled after it has been placed with the factory an administration fee of 30% of the product value may be applied.